

MY20 CONQUEROR OFF-GRID UEV-490

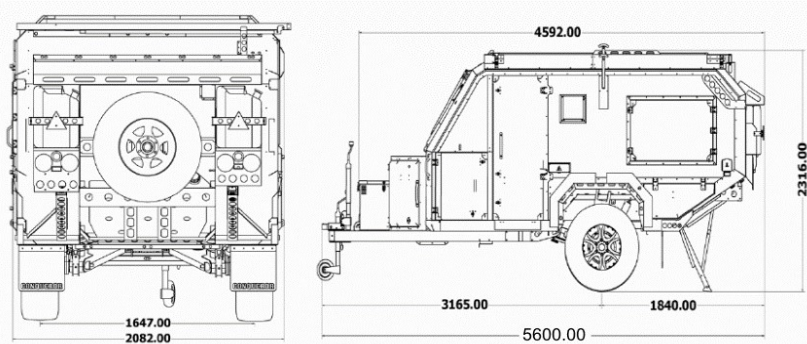

	UEV-490	UEV-490 SAHARA
PRICE	\$ 75,990	\$ 93,990

TARE WEIGHT (KG):	1500 -1700
ATM:	2250 Kg

CHASSIS & SUSPENSION

Fully galvanized box section chassis and "A" Frame.		✓	✓
Independent trailing arm suspension with Fox Racing off-road performance shocks, with rolling sleeve airbags		✓	✓
ELECTRIC OVER HYDRAULIC DISC BRAKES WITH HYDRAULIC HANDBRAKE		✓	✓
FOX OEM 2.0 SHOCKS		✓	—
FOX OEM 2.0 RESIVOIR ADJUSTABLE SHOCKS	\$ 975.00	○	✓
Full Rolling Sleeve Airbags with onboard Compressor and controls		✓	✓
Upgrade Airbag suspension (wirelessBluetooth App control) <i>From Manual Control</i>	\$ 1,800.00	○	○
12 inch Disc brakes (Electric/hydraulic) including hydraulic handbrake		✓	✓
12 inch marinized stainless steel ventilated disc brakes including stainless calliper & ceramic baked disc pads (electric over hydraulic) <i>UPGRADE FROM STANDARD 12 INCH DISCS</i>	\$ 1,500.00	○	○
Witi wireless braking system with integrated security system	\$ 599.00	○	○
Gps Tracking (needs Witi)	\$ 249.00	○	✓
WITI Brake controller including off road down hill assist for trailer unit (Fitting extra)	\$ 200.00	○	○
Witi Security System		✓	✓
285/75/16's on Heavy Duty Alloy Rims		✓	✓
Spare wheel carrier serving as emergency stub axle.		✓	✓
DO35 off-road hitch.		✓	✓
Front & rear adjustable stabilisers.		✓	✓

CANVAS & AWNINGS

360* Insta Awn Awning	\$ 6,000.00	○	○
360* Insta Insta Awn full wall kit including draft skirts	\$ 4,800.00	○	○
270* Awning to kitchen side		✓	✓
270* Wall kit including draft skirt	\$ 2,000.00	○	✓
Rally style Awning with full wall kit to Bathroom Side	\$ 1,550.00	○	✓
Quick Pitch Quick Ensuite mounted to bathroom side (Works without additional awnings fitted)		✓	✓
Tropical Fly over front Bed		✓	✓
Midge Mesh to all windows and doors		✓	✓
Ground Sheets x2	\$ 180.00	○	✓

— Not Available

○ Optional

✓ Included

Prices and Specs may vary without Notice

	PRICE	UEV-490	UEV-490 SAHARA
ELECTRICAL SYSTEM			
Adventure Engineering "Vision" power pack with inbuilt 45amp dc/dc charger, Mppt solar charger, Water level gauge & 30 amp Victron Lithium Battery Charger & BMV-712 Bluetooth Smart Battery Monitor.		✓	✓
200ah Victron Lithium Battery		✓	✓
2nd 200ah Victron Lithium (2x200ah including external BMS) 40kg	\$ 3,300	○	✓
Victron 800va Phoenix Inverter		✓	-
Victron 1200va Phoenix Inverter	\$ 900	○	-
Victron MultiPlus 1600va/70amp inverter/charger (Per unit, 2 Max)	\$ 1,980	○	✓
350w roof mounted solar. (With Additional Victron Smart Solar Mppt)		✓	✓
700W roof mounted solar UPGRADE FROM 350W	\$ 1,550	○	✓
2 usb charging points		✓	✓
240v GPO including 2 built-in usb charging points		✓	✓
External LED lights on both sides (dual colour white/orange)		✓	✓
COMFORT & ENTERTAINMENT			
Rooftop Air Conditioning 240V SYSTEM	\$ 4,500	○	○
Rooftop Air Conditioning 12v recommend 400ah Lithium and inverter charger upgrade	\$ 4,500	○	✓
Eberspacher HS3 is the latest in Diesel hotwater and cabin heating technology combined with the new variable air heater with thermostaic control	\$ 5,850	○	✓
Hi Def TV		✓	✓
Stereo		✓	✓
Minibar Fitted to inside main door		✓	✓
Autosat Automatic Satellite TV	\$ 5,000	○	○
Dining area converts to either 2 singles or a double bed		✓	✓
Sahara Premium Mattresses	\$ 1,200	○	✓
Conqueror Branded Fitted Bedding		✓	✓
KITCHEN & COOKING			
Conveniently laid-out retractable kitchen drawer with dedicated fridge storage		✓	✓
90Lt National Luna Single Door Dual Zone Fridge Freezer (upgrade from Snomaster)	\$ 890	○	✓
82.5Lt Snomaster Dual lid Dual Zone Fridge Freezer	\$ 2,250	✓	✓
Cutlery & Crockery supplied in custom fitted draws		✓	✓
6 Seater Aluminium Dining Table built into front wall of front Bed		✓	✓
Single Burner Induction Cooktop	\$ 300	○	○
Upgrade Cooker to 2 Burner Induction Cooktop (upgrade from gas cooktop)	\$ 2,250	○	○
Microwave Oven fitted RHS of the van	\$ 600	○	○

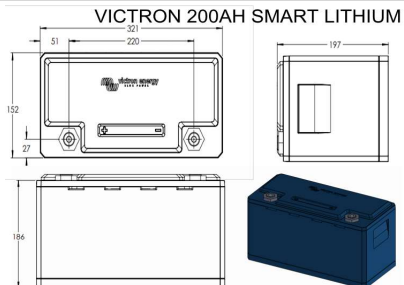

- Not Available

○ Optional

✓ Included

	PRICE	UEV-490	UEV-490 SAHARA
PLUMBING			
Low centre of gravity 150 litre water tanks		✓	✓
Auto shut-off water pump		✓	✓
Integrated plumbing for Kitchen and Bathroom		✓	✓
HOT WATER OPTIONS LISTED ABOVE IN COMFORT AND ENTERTAINMENT			
STORAGE & ACCESSORIES			
Large 450 litre nosecone with dedicated axe and spade mountings		✓	✓
2X 20L Diesel Jerry Cans		✓	✓
Canvas multi pocket storage hanger on both main doors and Kitchen Door		✓	✓
2x Storage boxes behind axles		✓	✓
12 internal cupboards & 6 internal shelves		✓	✓
Axe fitted to Front nose Cone		✓	✓
Spade Fitted under roof of front nose cone		✓	✓
Rear Storage rack		✓	✓
198 litre grocery cupboard		✓	✓
Dedicated bottle storage		✓	✓
Dust Limiting cabin pressure fan		✓	✓
BBQ Grill <i>Fitted to Spare Wheel</i>		✓	✓
Keyed alike padlock set		✓	✓
SHOWER			
Externally located, hot and cold water shower		✓	✓
Retractable stainless steel washbasin with storage compartment		✓	✓
Easy to reach vanity located in access door		✓	✓
CANVAS OPTIONS FOR SHOWER/BATHROOM LISTED ABOVE IN CANVAS SECTION			
CONSTRUCTION AND WARRANTY			
5 YEAR WARRANTY & AUSTRALIA WIDE ROAD SIDE ASSISTANCE PACKAGE T,s & C,s		✓	✓
Apply			
Fully independent patented suspension with Full Rolling Sleeve OEM Airbags and onboard compressor and full controls, trailing arms and torsion bar for improved handling (SAHARA HAS FOX 2.0 ADJUSTABLE REMOTE RES SHOCKS AS STANDARD)		✓	✓
World Renowned Fox Racing Shocks used in all Models		✓	✓
Specially designed spare wheel carrier which doubles as an emergency stub axle		✓	✓
Hot dipped galvanised Boxed A-Frame and Chassis		✓	✓
The Conqueror UEV-490 is manufactured using a combination of aluminium and motor industry grade electro galvanized steel		✓	✓
All parts are epoxy coated or better known as powder coated and is more resistant against scratches, chipping, wear and fade compared to other finishes		✓	✓
Components are of a modular design allowing for easy panel replacements in case of accident damage		✓	✓
No wood, fibreglass or other degradable materials are used		✓	✓
Only stainless-steel bolts & nuts are used during assembly		✓	✓
All door apertures are sealed using motor industry grade door seals		✓	✓
Structural components are designed and manufactured for maximum strength with minimal weight.		✓	✓
Our unique design and assembly techniques borrowed from the aeronautical industry, significantly reduces metal fatigue and improves body flex resulting in a more durable and longer lasting camper		✓	✓

– Not Available

○ Optional

✓ Included